

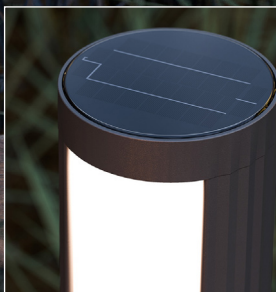

RADIA™ BOLLARD

PRODUCT DATA





RADIA™ BOLLARD

PRODUCT DATA

Radia Bollards blend an elegant cove-style design with coordinated options for solar-powered and hardwired performance. Bollard bodies are powdercoated aluminum with a subtle faceted surface that plays with shadows and light and adds visual interest to the day form. By night, the illuminated cove creates a cascading gradient of light and 180° light spread on the ground. The color of the cove interior can be the same as the body or white—an option that maximizes reflectivity and light output. Solar and hardwired Radia Bollards are sized to suit different lighting scenarios and are ideal for bringing LED illumination across a property. Radia Bollards with 3000K LEDs are approved by the International DarkSky Association to minimize light pollution. Radia Pathway Bollards with the same cove-style design expand the family’s reach.

MATERIAL & CONSTRUCTION DETAILS

INSTALLATION & MAINTENANCE

<p>CONFIGURATIONS</p> <ul style="list-style-type: none"> Bollards are available in solar-powered or hardwired configurations. Solar bollard dimensions are 36.5" high x 6.8" diameter; hardwired bollard dimensions are 28.9" high x 4.4" diameter. Weight: solar-powered bollard is 27.6 lbs.; hardwired bollard is 10 lbs. 	<p>SOLAR BOLLARD COMPONENTS</p> <ul style="list-style-type: none"> Cree® LEDs in 3000K warm white and 4000K neutral white color temperatures. Integrated high-efficiency LED driver. High-efficiency monocrystalline cells encapsulated in high-impact, UV resistant polyurethane. High-performance lithium ion phosphate battery with over-discharge and over-current protection. High-efficiency Maximum Power Point Tracking (MPPT) charge controller. Solar Lighting Controller (SLC) is self-learning with intelligent day/night detection. 	<p>INSTALLATION</p> <ul style="list-style-type: none"> Bollards must be surface mounted using three tamper-resistant bolts. For hardwired bollards, installation of a surge protector as part of each unit's wiring is recommended. Stainless steel mounting hardware sold separately. Templates available upon request.
<p>MATERIALS & FINISHES</p> <ul style="list-style-type: none"> Base and top cap are corrosion-resistant cast aluminum with a powdercoat finish. Body is extruded aluminum with a powdercoat finish. Interior cove can be wet-coated white or powdercoated to match the body exterior. See the Forms+Surfaces Powdercoat Chart for details. Custom RAL colors are available for an upcharge. Due to the inherent nature of metal castings, gloss powdercoats are not offered for cast components. Solar bollard lens is clear acrylic, hardwired bollard lens is frosted acrylic. 	<p>HARDWIRED BOLLARD LED LAMPS & DRIVER</p> <ul style="list-style-type: none"> Cree® LEDs in 3000K warm white and 4000K neutral white color temperatures. 9W LED driver is IP64-rated. LED driver input power is 120-277 VAC. Driver has forward phase, reverse phase, and 0-10V dimming capabilities. 	<p>MAINTENANCE</p> <ul style="list-style-type: none"> Metal surfaces can be cleaned as needed using a soft cloth or brush with warm water and a mild detergent. Avoid abrasive cleaners.

LIGHT ENGINE DESCRIPTION - SOLAR BOLLARD

LAMPS	DESCRIPTION	LUMINAIRE LUMENS*	B.U.G. RATINGS
3000K LED	Custom LED light engine	45	B0-U1-G0
4000K LED	Custom LED light engine	45	B0-U1-G0

LIGHT ENGINE DESCRIPTION - HARDWIRED BOLLARD

LAMPS	DESCRIPTION	LUMINAIRE LUMENS*	B.U.G. RATINGS
3000K LED	9W custom LED light engine	95	B0-U1-G0
4000K LED	9W custom LED light engine	95	B0-U1-G0

*Luminaire lumens represents the absolute photometry for the luminaire, and indicates the lumens out of the entire fixture.



NOMINAL DIMENSIONS

SOLAR BOLLARD

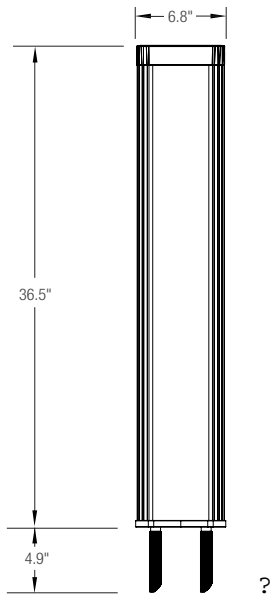

HARDWIRED BOLLARD

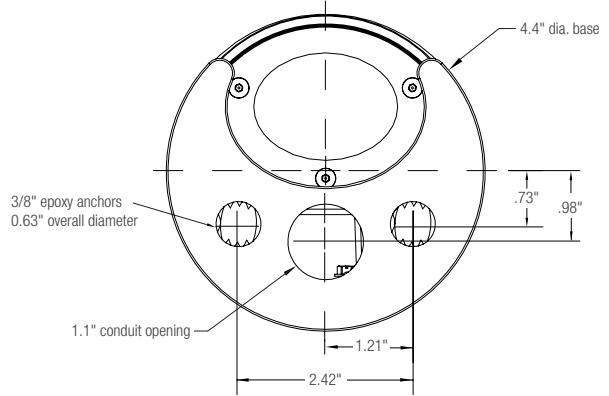
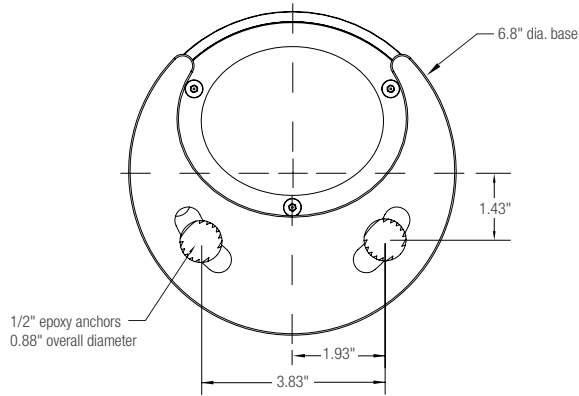
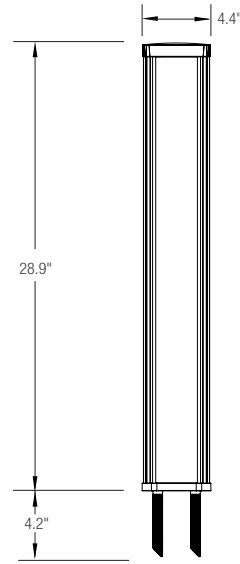



RADIA™ BOLLARD

PRODUCT DATA

CERTIFICATION

- Hardwired Radia Bollard is ETL and C-ETL listed for wet locations.
- Radia Bollard 3000K is International DarkSky Approved.



**DARKSKY
APPROVED**
Reduces light pollution
Certified by DarkSky.org

ENVIRONMENTAL CONSIDERATIONS

- Please refer to the Radia Bollard Environmental Data Sheets for detailed environmental impact information.
- Metal components have a long life cycle and are 100% recyclable.
- Standard powdercoat finishes are no-VOC; non-standard powdercoat finishes are no- or low-VOC, depending on color.
- Low maintenance.

MODEL NUMBERS AND DESCRIPTIONS

MODEL	DESCRIPTION
LBRAD-AC	Radia Bollard, hardwired
LBRAD-S	Radia Bollard, solar

PRODUCT OPTIONS

The following options are available for an upcharge

Custom RAL powdercoat color	Add stainless steel mounting hardware
-----------------------------	---------------------------------------

LEAD TIME: 6 to 8 weeks. Shorter lead times may be available upon request. Please contact us to discuss your specific timing requirements.

PRICING: Please contact us at **800.451.0410** or **sales@forms-surfaces.com**. At Forms+Surfaces, we design, manufacture and sell our products directly to you. Our sales team is available to assist you with questions about our products, requests for quotes, and orders. Territory Managers are located worldwide to assist with the front-end specification and quoting process, and our in-house Project Sales Coordinators follow your project through from the time you place an order to shipment.

TO ORDER SPECIFY: Model, quantity, powdercoat color and color temperature. Quote/Order Forms are available on our website to lead you through the specification process in a simple checkbox format.