

# VECTOR SEATING SYSTEM

## CAUTIONS & WARNINGS

- Forms+Surfaces is not responsible for site preparation and footings.
- Forms+Surfaces is not responsible for any injuries or damage to property incurred while wiring or installing luminary, or resulting from incorrect wiring or installation.
- Before proceeding with wiring of luminary, check to ensure that all applicable site wiring and safety codes have been followed. Installation should be performed only by qualified individuals.

## STEP BY STEP FOR VECTOR SEATING SYSTEM CONFIGURATIONS WITH A STANDALONE BENCH

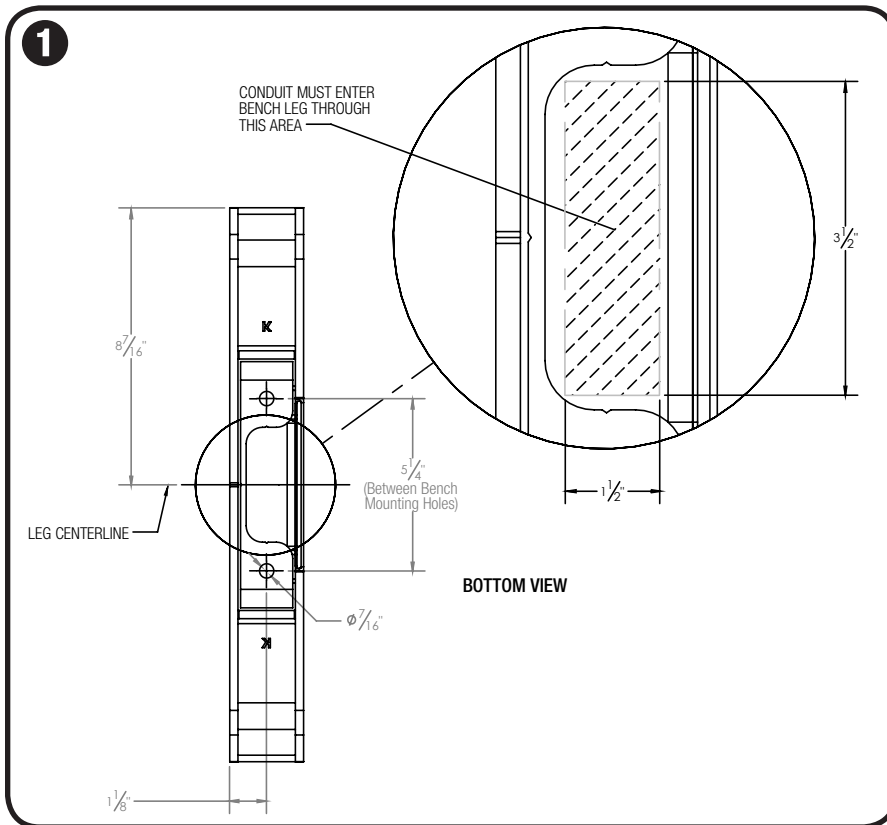

### Prepare Incoming Power

- Before pouring concrete footer, run properly sized conduit and cabling to each bench leg containing an LED driver according to local code requirements. Refer to bottom view figure with dimensions for conduit entry envelope size and location on bench leg.

Note: Conduit should not protrude more than 2" above mounting surface.

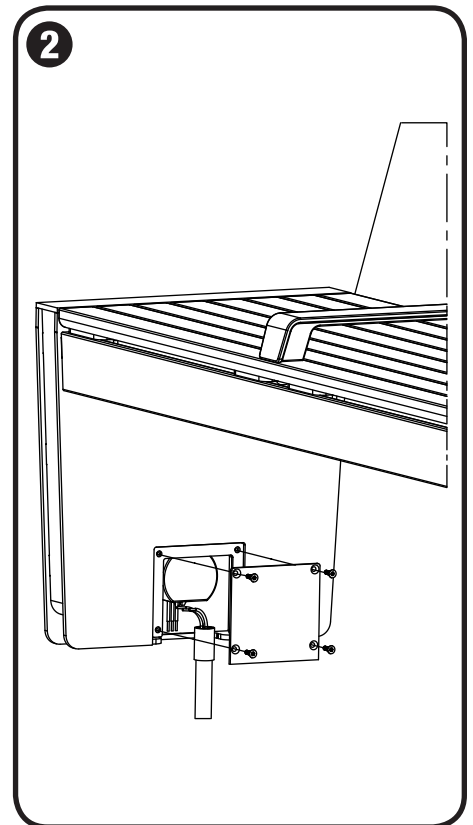

### Locate Wires

- Remove four screws on access door at base of leg, and remove access door.
- Locate black, white, and green wires from driver.

Note: Driver rated for 100-277VAC supply power at 1.5 amps. Installation of a surge protector as part of each unit's wiring is recommended.

# VECTOR SEATING SYSTEM

## STEP BY STEP FOR VECTOR SEATING SYSTEM CONFIGURATIONS WITH A STANDALONE BENCH

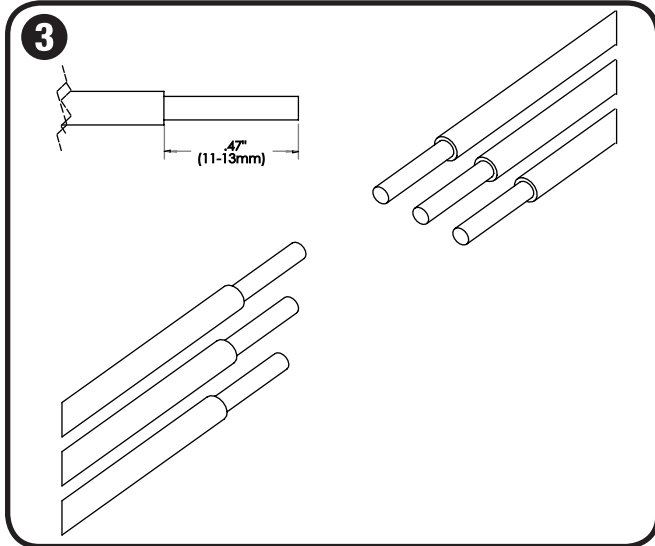

### Prepare Wires

- Prepare wiring from site junction box and bollard by stripping and removing .47" (11-13mm) of insulation. Wire used should be 22-14 AWG copper conductors.

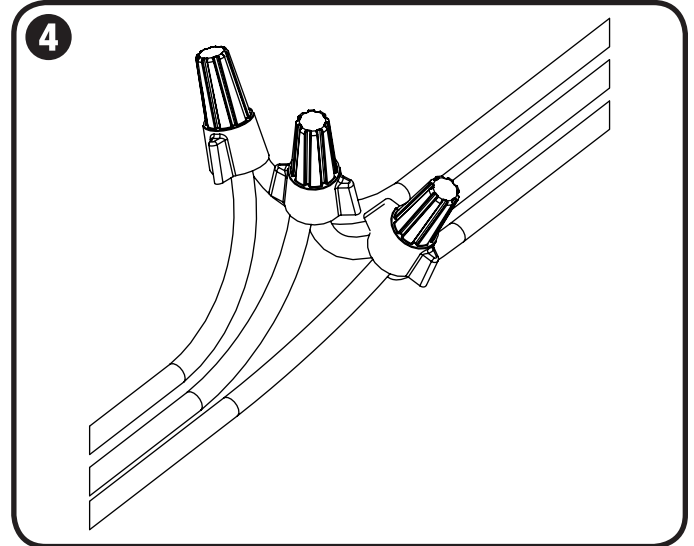

### Connect Wires

- Insert ground (green), neutral (white), and positive (black) wires into provided wire nuts, being sure to match wire color codes from junction box to bollard.
- Tighten wire nuts until exposed wire ends are below bottom of wire nut.
- Inspect all wiring and connections before turning power supply on.
- Refer to installation instructions for additional information.

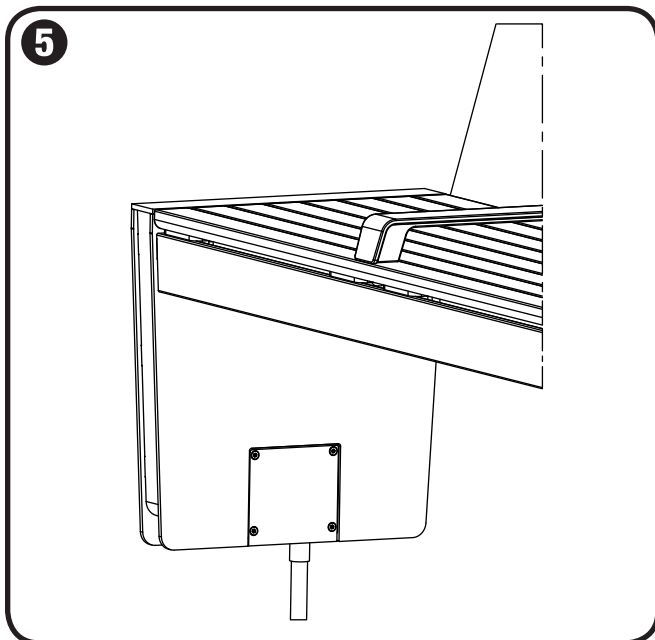

### Re-Install Access Door

- After testing bench lighting, re-install access door with four original screws.