

CITRUS™ TABLE

FREESTANDING INSTALLATION INSTRUCTIONS

MATERIALS INCLUDED

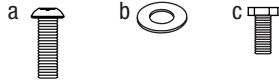

TOOLS NEEDED



7/32" hex key



1/2" nut driver

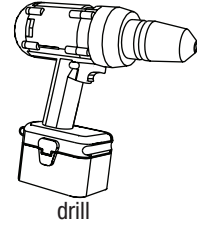

drill

STEP BY STEP FOR ALL FREESTANDING CITRUS TABLES

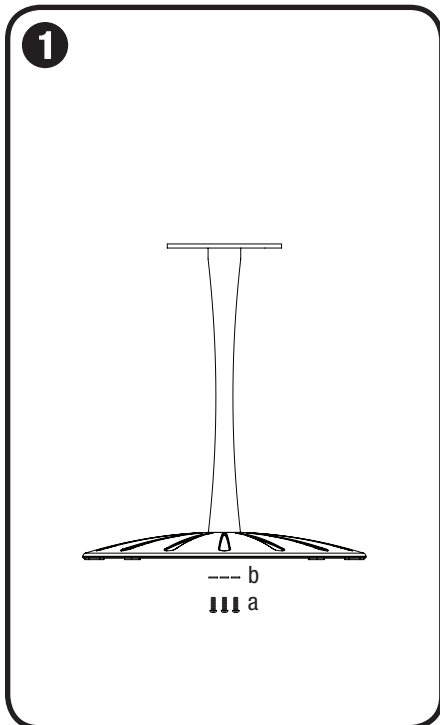

Attach base to column

- Slide 3/8" stainless steel flat washer (b) onto each 3/8"-16 x 1-1/2" button head cap screw (a) and attach base to column using 7/32" hex key.

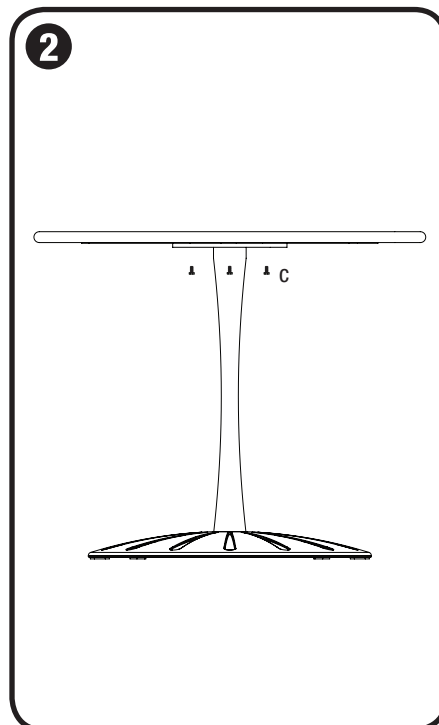

Attach table top to column

- Use drill with 1/2" nut driver (or socket wrench with 1/2" socket) to attach table top to column with 5/16"-18 x 3/4" hex head bolts (c).

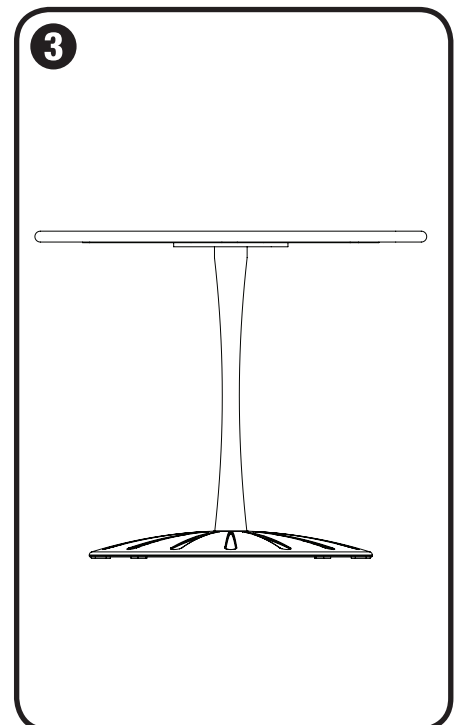

Tighten screws

- Tighten all screws until snug.